

# FLUID COOLING | Industrial AO Series

AIR COOLED AO/AOR

## FEATURES

- Young Interchange – OCH
- Adjustable Louvers
- Medium Flow Rates
- Moderate Heat Removal
- One or Two Pass
- Fluid Power Systems
- Gear Drives
- Injection Molding Machines
- Machine Tools
- Torque Converters
- Hydraulic Presses

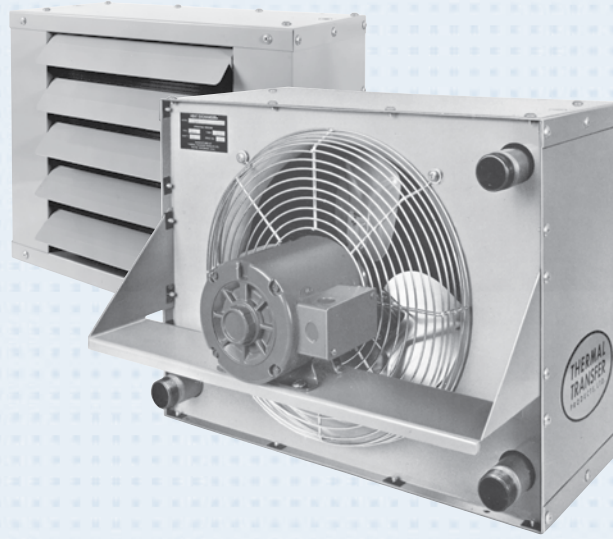

## OPTIONS

- SAE & Metric Connections
- Relief Bypass
- Foot Brackets
- Corrosive Resistant
- Marine Coating

## Ratings

- Operating Pressure** - 300 psi
- Test Pressure** - 300 psi
- Operating Temperature** - 400° F

## Materials

- Tubes** Copper
- Fins** Aluminum
- Turbulators** Steel
- Fan Blade** Aluminum with steel hub
- Fan Guard** Zinc plated steel
- Cabinet** Steel with baked enamel finish
- Manifolds** Steel
- Connections** Steel

## Weights

MODEL	Net Weight (LBS)
AO-5	47
AO-10	62
AO-15	72
AO-20	86
AO-25	120
AO-30	135
AO-35	160
AO-40	185

## One Pass (Medium to High Oil Flows)

Model Number	Flow Range GPM (USA)
AOR - 5-1	2 - 80
AOR - 10-1	3 - 80
AOR - 15-1	4 - 80
AOR - 20-1	5 - 80
AOR - 25-1	6 - 100
AOR - 30-1	7 - 100
AOR - 35-1	8 - 112
AOR - 40-1	9 - 118

## Two Pass (Low to Medium Oil Flows)

Model Number	Flow Range GPM (USA)
AOR - 5-2	2 - 25
AOR - 10-2	2 - 30
AOR - 15-2	2 - 30
AOR - 20-2	2 - 40
AOR - 25-2	2 - 40
AOR - 30-2	2 - 40
AOR - 35-2	3 - 40
AOR - 40-2	4 - 40

### One Pass

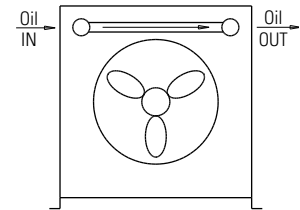

### Two Pass

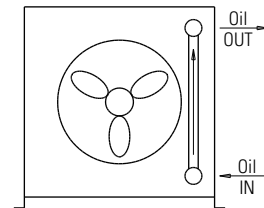

# Specifications

## Electric motor & Fan data\*

Model	CFM	Sound dB(A)** at 7 ft.	Horse Power	Volts	Phase	Full Load Amps	Hz	Nema Frame	RPM	Type	Circuit	Thermal Overload	Bearing B-Bal S-Sleeve
A0-5	401/487 494	68 70	1/12 1/4	110/115 208-230/460	1 3	1.2/1.2 1.4-1.3/.65	50/60 60	48	1400/1700 1725	TEAO TEFC	A D	No	B
A0-10	576/700 710	68 70	1/12 1/4	110/115 208-230/460	1 3	1.2/1.2 1.4-1.3/.65	50/60 60	48	1400/1700 1725	TEAO TEFC	A D	No	B
A0-15	824/1000 1015	69 71	1/12 1/4	110/115 208-230/460	1 3	1.2/1.2 1.4-1.3/.65	50/60 60	48	1400/1700 1725	TEAO TEFC	A D	No	B
A0-20	1555	70 72	1/6 1/4	115/208-230 208-230/460	1 3	4/2.1-2 1.4-1.3/.65	60 60	48	1725	TEFC TEFC	C D	No	B
A0-25	2240	72 73	1/6	115/208-230 208-230/460	1 3	4.6/2.2 1.3-1.2/.6	60	48	1140	TEFC	C D	No	B
A0-30	3100	75 76	1/6	115/208-230 208-230/460	1 3	5.2/2.7-2.6 1.3-1.2/.6	60	48	1140	TEFC	C D	No	B
A0-35	4370	76 77	1/2	115/208-230 208-230/460	1 3	8/4.2-4 2.5-2.4/1.2	60	56	1140	TEFC	C D	No	B
A0-40	5450	78 79	1/2	115/208-230 208-230/460	1 3	8/4.2-4 2.5-2.4/1.2	60	56	1140	TEFC	C D	No	B

\*Published electrical ratings are approximate, and may vary because of motor brand. Actual ratings are on motor nameplate.

\*\*Catalog dB(A) sound levels are at seven (7) feet. dB(A) sound levels increase by six (6) dB(A) for halving this distance and decrease by six (6) dB(A) for doubling this distance.

## Explosion Proof Motors (Class I GP.D & Class II GP.F, G)\*

Model	CFM	Sound dB(A)** at 7 ft.	Horse Power	Volts	Phase	Full Load Amps	Hz	Nema Frame	RPM	Type	Circuit	Thermal Overload	Bearing B-Bal S-Sleeve
A0-5	494	68 70	1/4	115/230 208-230/460	1 3	5.8/2.9 1.4-1.3/.65	60	48	1725	FC	C D	Yes	B
A0-10	710	68 70	1/4	115/230 208-230/460	1 3	5.8/2.9 1.4-1.3/.65	60	48	1725	FC	C D	Yes	B
A0-15	1015	69 71	1/4	115/230 208-230/460	1 3	5.8/2.9 1.4-1.3/.65	60	48	1725	FC	C D	Yes	B
A0-20	1555	70 72	1/4	115/230 208-230/460	1 3	5.8/2.9 1.4-1.3/.65	60	48	1725	FC	C D	Yes	B
A0-25	2240	72 73	1/3	115/230 208-230/460	1 3	6.8/3.4 1.8-1.6/.8	60	56	1140	FC	C D	Yes	B
A0-30	3100	75 76	1/3	115/230 208-230/460	1 3	6.8/3.4 1.8-1.6/.8	60	56	1140	FC	C D	Yes	B
A0-35	4370	76 77	1/2	115/230 208-230/460	1 3	8/4 2.5-2.4/1.2	60	56	1140	FC	C D	Yes	B
A0-40	5450	78 79	1/2	115/230 208-230/460	1 3	8/4 2.5-2.4/1.2	60	56	1140	FC	C D	Yes	B

\*Published electrical ratings are approximate, and may vary because of motor brand. Actual ratings are on motor nameplate.

## 575 Volt

Model	CFM	Sound dB(A)** at 7 ft.	Horse Power	Volts	Phase	Full Load Amps	Hz	Nema Frame	RPM	Type	Circuit	Thermal Overload	Bearing B-Bal S-Sleeve
A0-5	494	70	1/4	575	3	.52	60	48	1725	TEFC	D	No	B
A0-10	710	70	1/4	575	3	.52	60	48	1725	TEFC	D	No	B
A0-15	1015	71	1/4	575	3	.52	60	48	1725	TEFC	D	No	B
A0-20	1555	72	1/4	575	3	.52	60	48	1725	TEFC	D	No	B
A0-25	2240	73	1/2	575	3	.88	60	56	1140	TEFC	D	No	B
A0-30	3100	76	1/2	575	3	.88	60	56	1140	TEFC	D	No	B
A0-35	4370	77	1/2	575	3	.88	60	56	1140	TEFC	D	No	B
A0-40	5450	79	1/2	575	3	.88	60	56	1140	TEFC	D	No	B

\*D Squirrel Cage

\*\*Catalog dB(A) sound levels at seven (7) feet. dB(A) sound levels increase by six (6) dB(A) for halving this distance, and decrease by six (6) dB(A) for doubling this distance.

## Lubrication Notes

**Caution:** Do not over oil or over grease. **Ball bearings** – No grease needed at start up. Grease as follows:

5,000 Hours/Year	5 Year Grease Interval
Continuous Normal Applications	2 Years
Seasonal Service Motor is idle for 6 months or more	1 Year
Continuous High ambients, dirty or moist locations, high vibration	6 Months

# Dimensions

Model	A	B	C	D	E	F	G	H	J	K	L	M NPT	M SAE	N	P	T
AO-5	7.40	14.81	5.90	11.81	20.00	9.19	8.31	6.47	12.94	3.78	7.56	1"	#16 SAE	5.84	11.69	—
AO-10	9.50	19.00	6.56	13.12	19.25	10.50	12.50	8.56	17.12	4.44	8.88	1"		1-5/16-12UN-2B	7.94	15.88
AO-15	10.19	20.38	7.87	15.75	19.25	13.12	13.88	9.25	18.50	5.75	11.50	1"	Thread	8.62	17.25	—
AO-20	11.91	23.81	9.19	18.38	19.25	15.75	17.91	10.90	21.81	7.00	14.00	1-1/4"	#20 SAE	10.28	20.56	—
AO-25	13.34	26.68	11.81	23.62	19.25	21.00	20.19	12.40	24.81	9.62	19.25	1-1/4"		1-5/8-12UN-2B	11.78	23.56
AO-30	15.81	31.62	13.78	27.56	19.50	24.94	25.12	14.87	29.75	11.59	23.19	1-1/4"	Thread	14.25	28.50	11.00
AO-35	16.90	33.81	15.09	30.19	21.50	27.56	27.31	15.97	31.94	12.90	25.81	1-1/4"		15.34	30.69	11.00
AO-40	20.81	41.62	18.37	36.75	20.50	34.12	35.12	19.87	39.75	16.19	32.38	1-1/4"		19.25	38.50	13.25

NOTE: All dimensions in inches.

## Installation Piping Diagram

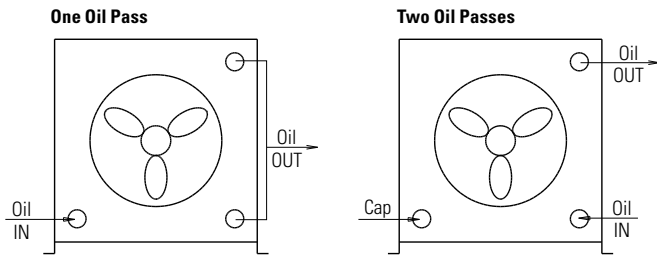

\*See dimension chart for NPT or optional internal SAE connection size.

## Fan Rotation Clockwise/Facing Motor Shaft

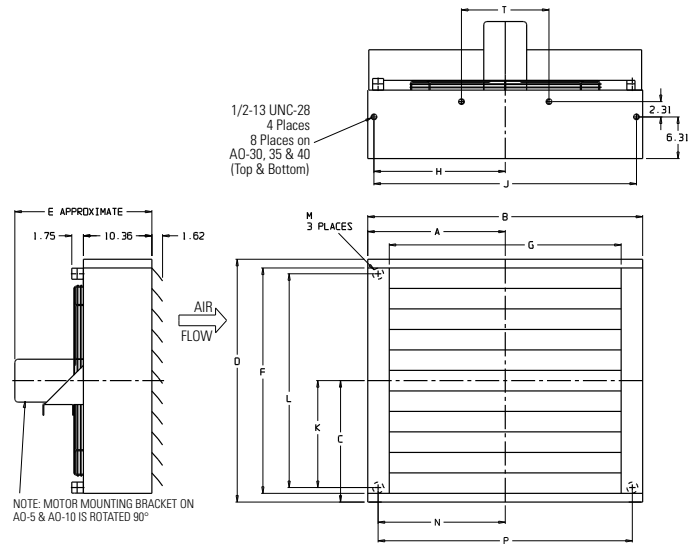

## C<sub>v</sub> Viscosity Correction

Average Oil Temp °F	OIL					
	SAE 5 110 SSU at 100°F 40 SSU at 210°F	SAE 10 150 SSU at 100°F 43 SSU at 210°F	SAE 20 275 SSU at 100°F 50 SSU at 210°F	SAE 30 500 SSU at 100°F 65 SSU at 210°F	SAE 40 750 SSU at 100°F 75 SSU at 210°F	50-50 Ethylene Glycol & Water
100	1.14	1.22	1.35	1.58	1.77	1.11
150	1.01	1.05	1.11	1.21	1.31	1.02
200	.99	1.00	1.01	1.08	1.10	.96
250	.95	.98	.99	1.00	1.00	.95

# Performance Curves

## One Pass Oil

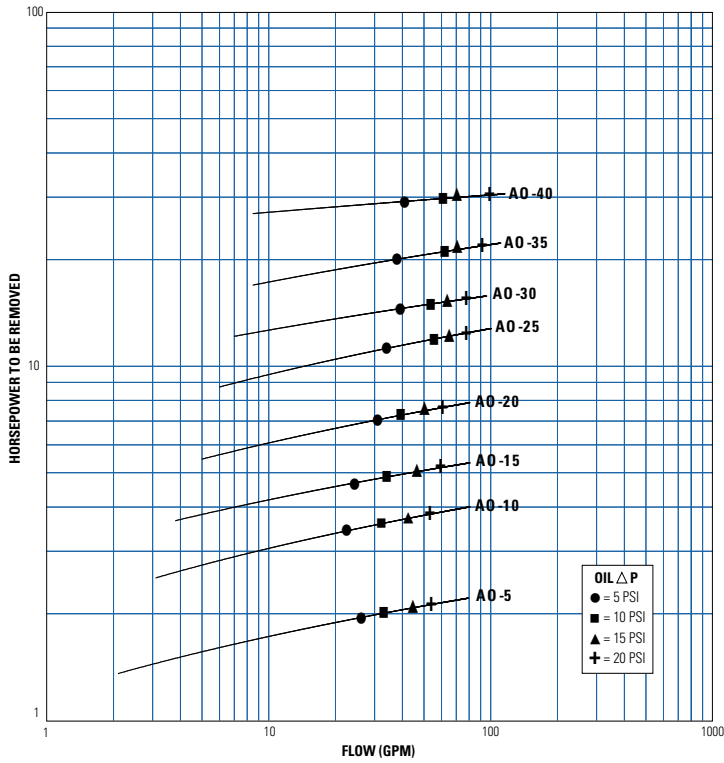

## Two Pass Oil

